

INSTALLATION, OPERATION
And
MAINTENANCE
MANUAL



1. INTRODUCTION

- A. GENERAL NOTE
- B. STRUCTURE / TYPE
- C. OPERATION

2. INSTALLATION

- A. PRE-INSPECTION
- B. INSTALLATION

3. MAINTENANCE / INSPECTION

- A. MAINTENANCE
- B. INSPECTION / MINOR TREATMENT

4. REPLACEMENT

- A. ISOLATION OF VALVE FROM PIPE
- B. DISASSEMBLY OF THE SEAT & INSERT RING
- C. REPLACEMENT

A. General Note

Having a unique double-seat structure, Unicom's Highseal valves bring an excellent performance in critical flow control and regulation. A simplicity and compactness in valve structure enables an easy assembly and disassembly work.

B. Structure / Type

The body style is classified as Wafer Type, Lug Type and Flange Type by its body shape. Its principal parts are body, disc, seat and shaft, and materials of those parts are determined according to the working condition.

C. Operation

The valve operator could be classified into a lever handle, manual gear, and pneumatic and electric actuator. Valve is operated simply by rotating the disc with the actuator. (Generally, on-off direction is indicated on the operator)

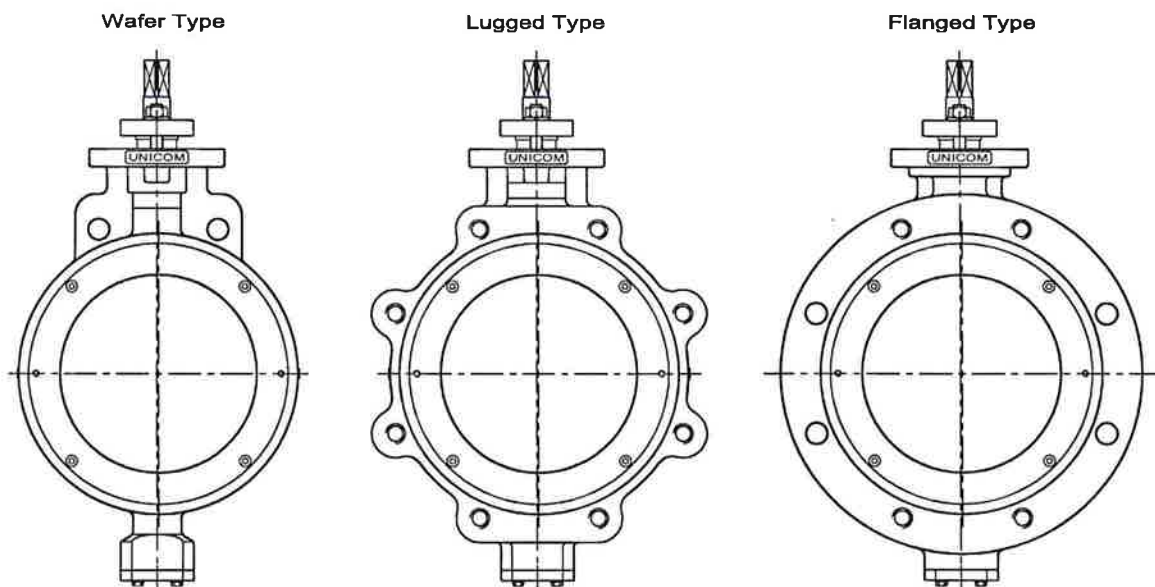

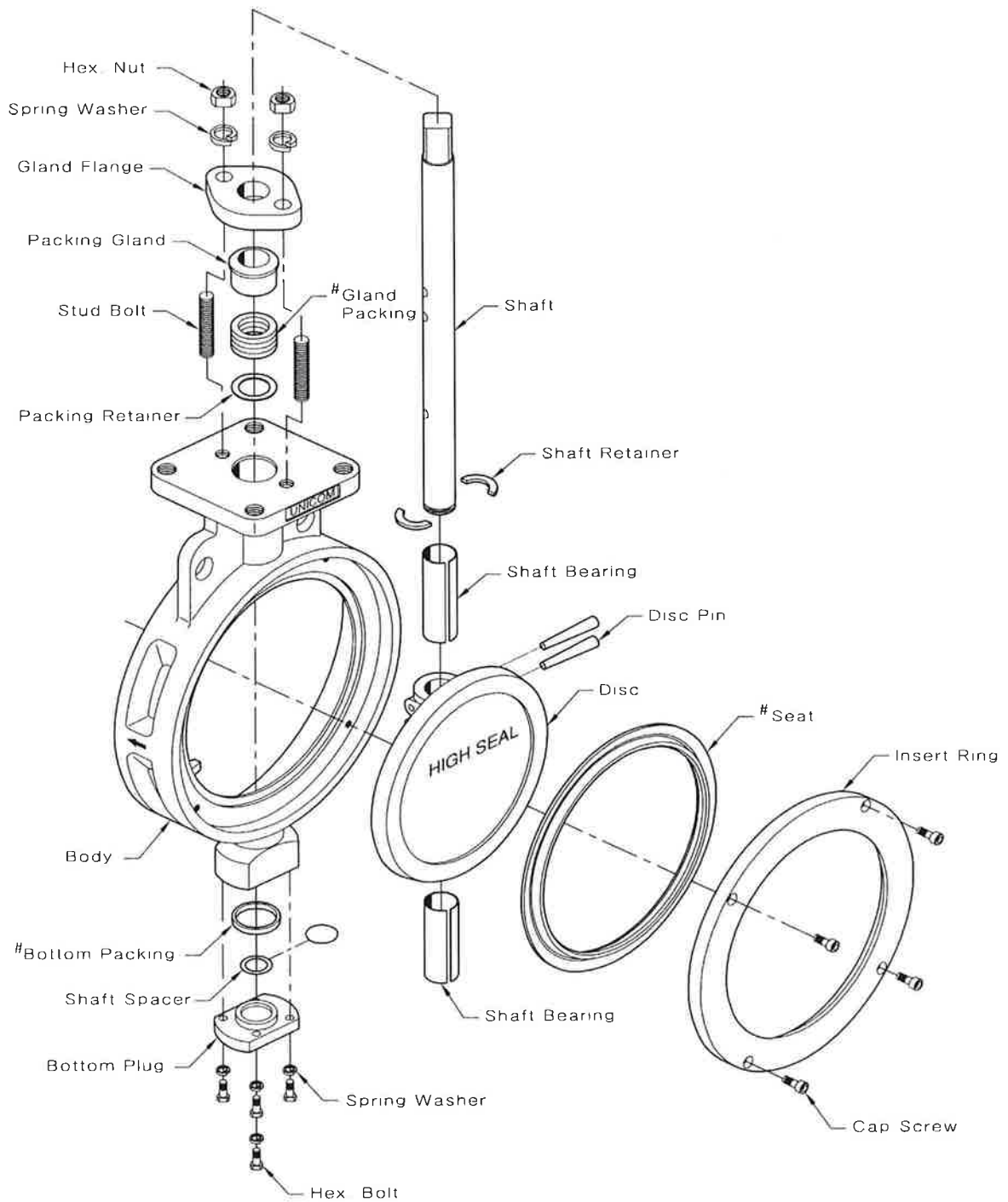

■ **Note:**

The items '#' marked are recommended spare parts.

A. Pre-Inspection

It is recommended to inspect a valve before installing the valve to the 'Pipe Line.

1. Inspecting Valve & Accessory

- Examine whether the valve gets any damage during delivery.
- Clean the valve with an air blaster or smooth dust cloth / mop before installation.
- Check the tightness of all kinds of bolts and nuts.

2. Inspecting Pipeline

- Remove foreign materials such as a rust, welding chip, etc, which remain in the pipe or flange.
- Make it sure that pipe flange and gasket surface is clean.

▣ **Caution :**

When the flow is flowing through the line, any foreign material is subject to scratch the disc, seat and inner body, so that the scratch may cause leakage and shortening of the valve lifetime.

B. Installation

- Make it sure that the valve disc is in full close position.
(Usually, disc is in fully close position to protect a seat)
- Check the flow direction with an arrow marked on the body.
- Be sure to place a gasket between valve flange and pipe flange.
- When connecting the valve to the pipe, screw the bolt, stud and nut diagonally.
- See the reference figure.

▣ **Caution :**

- *Recommended flow direction is marked on the body.*
- *Over torque on the bolt might cause damage of gasket.*

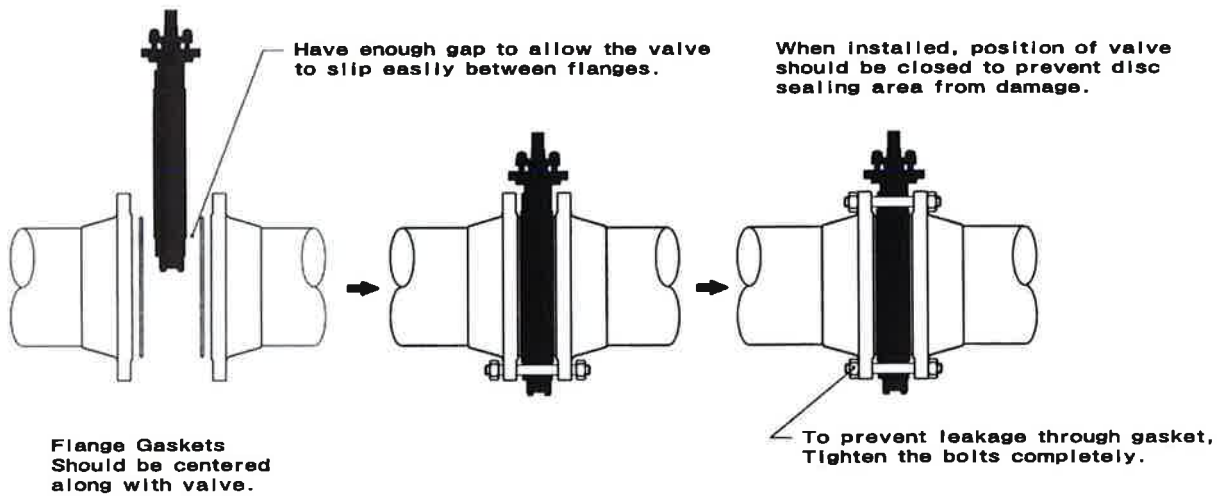
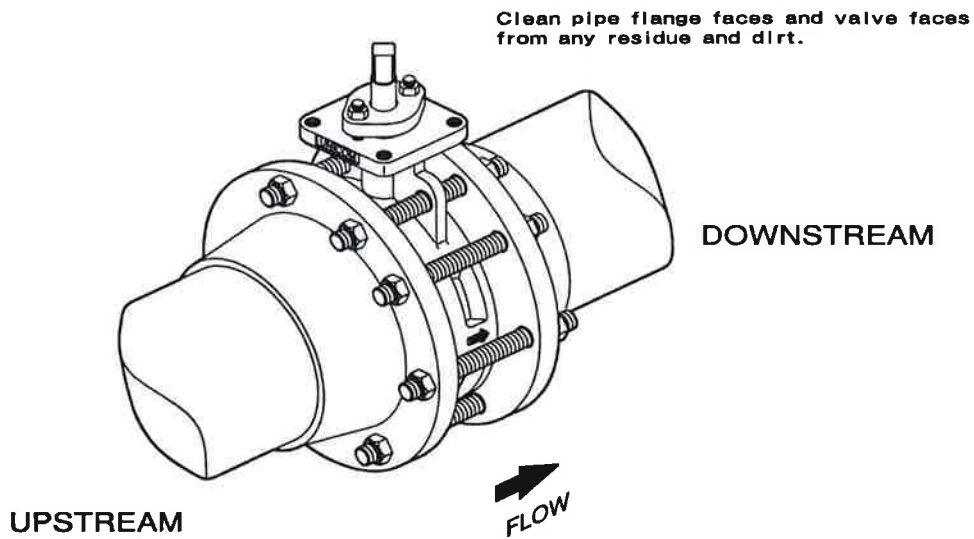

A. Maintenance

The Highseal valve doesn't need a particular maintenance unless any leak is found, however, some routine inspections are recommended for safety and longer lifetime as below;

- Visual inspection onto the body, disc and packing part of valve at the initial service or at the re-operation after long-term recess.
- Check up the valve when abnormal sound is perceived during the operation.
- Ensure tightness of each bolt regularly.

B. Inspection / Minor Treatment

1. Packing (Gland Packing / Bottom Packing)

Most leaks from packing parts of valve could be prevented effectively by tightening gland flange's nuts and bolts. If leaks don't stop in spite of re-tightening bolts, packing shall be replaced. In this case, refer to the reference figure and the method of packing replacement in page 9.

2. Seat / Insert Ring

If it sounds the leakage from inside of the valve after full closing of disc or if the medium flows over the drain valve, which is equipped at the bottom of piping, then check the seat condition and necessity of the replacement.

▣ **Remark :**

See Page 8, the section of disassembly of seat, for the replacement of seat.

- All repair works (disassembly and replacement, etc) should be performed by well-trained experts.

1. Separation of Valve from the Pipe

To repair valve leaking, the valve must be removed from pipeline and then parts should be in the following order;

- Shut down the line, and make sure no pressure inside.
- Drain all mediums from the pipe.
- Completely close the disc of the valve.
- Remove the operator and other accessories from the valve before removing the valve from pipe.
- Mark the location of each part on to the valve and pipe in order to install the parts at the same places as those parts were installed before.

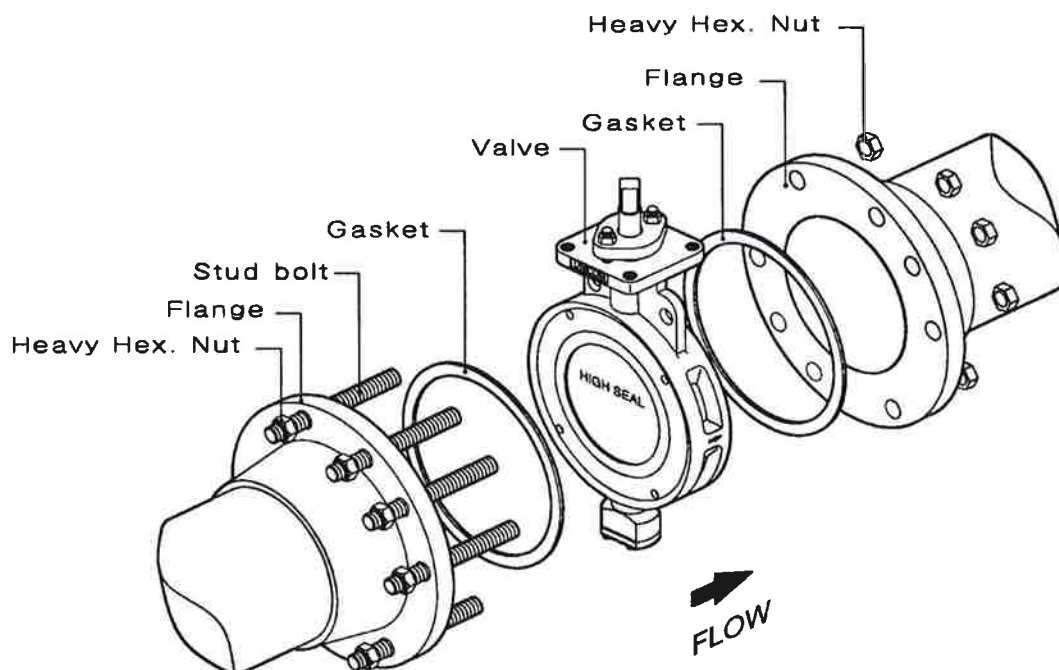

▣ **Caution :**

If the fluid is toxic, proper protection should be required before the removing valve.

2. Disassembly of the Seat & Insert Ring

- Open the disc of valve by 5~10° , using a rubber or urethane hammer.
- Remove a tightened ' cap screw' on the insert ring of the body.
- Put the ' Jacking tap' into the jacking tap hole, and pull up the insert ring up.
(See the below picture.)
- Take out the inner seat. At this time, be careful not to have the disc scratched, chopped and damaged.
- Clean the place where the seat is placed with an air blaster or smooth mop.
- Refer to the below picture for disassembling the insert ring & seat.

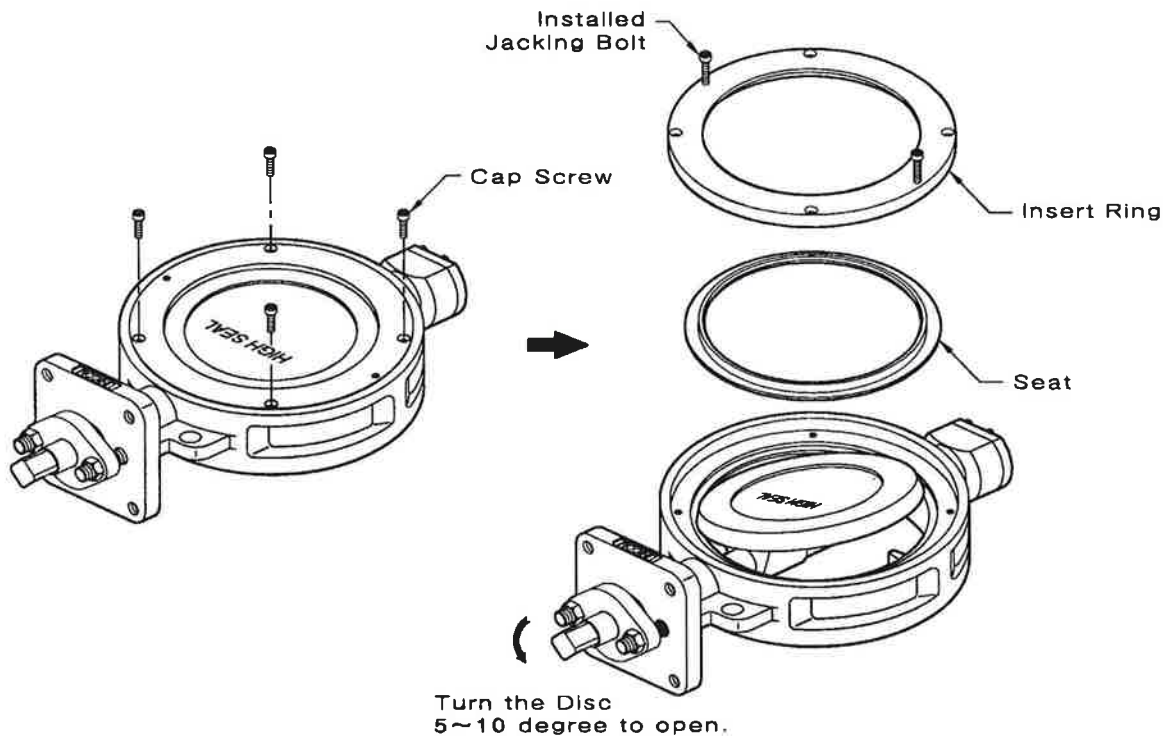

■ **Remark :**

After disassembly, please check the surface of disc. If disc gets any damage, then the disc and shaft must be replaced together. In this case, please be sure to get advice from Unicom.

3. Replacement

① Gland Packing Replacement :

For replacing gland packing, please take the following steps;

- i . Remove a Gland Flange after loosening a nut of gland flange.
- ii . Slightly lift the packing gland up and remove it by hand.
- iii . Remove packing stuffs using a packing extractor such as the corkscrew, awl and gimlet.
- iv . When you remove the packing with tools (packing extractor), please be careful not to scratch and damage the wall of 'packing housing' and the 'shaft'. Any damage on those parts may cause a leakage.
- v . By pushing a packing gland, carefully insert a set of packing after cleaning 'Packing Housing'.
- vi . After inserting the packing, assemble the packing gland and gland flange.
- vii . Nuts of gland flange should be tightened enough to push a packing gland downward, but over tightness of nuts might cause over torque to operate valve.

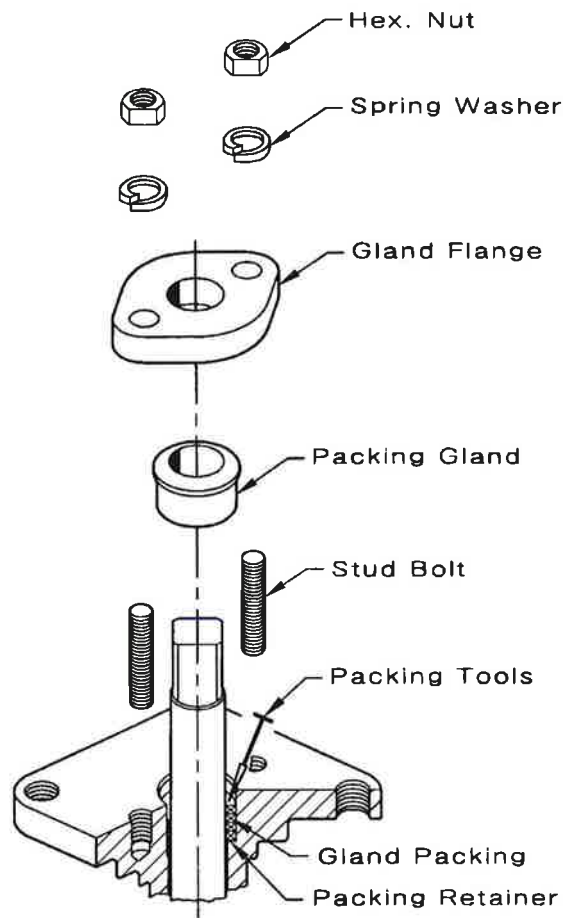

■ **Note :**

Please use 'Spare Part Kit' supplied by 'Unicom'

② Bottom Packing Replacement

For replacing bottom packing, please take the following steps;

- i. Remove a bolt and bottom plug.
- ii. By using a packing extractor such as the corkscrew, awl and gimlet, remove the packing. At this time, please be careful not to scratch and damage the wall of packing housing and the valve shaft.
- iii. After removing the packing, clean the place where the packing was placed before inserting a new packing.
- iv. Insert a new packing kit by tapping.
- v. Put the shaft spacer, and tighten the bottom plug with bolts.

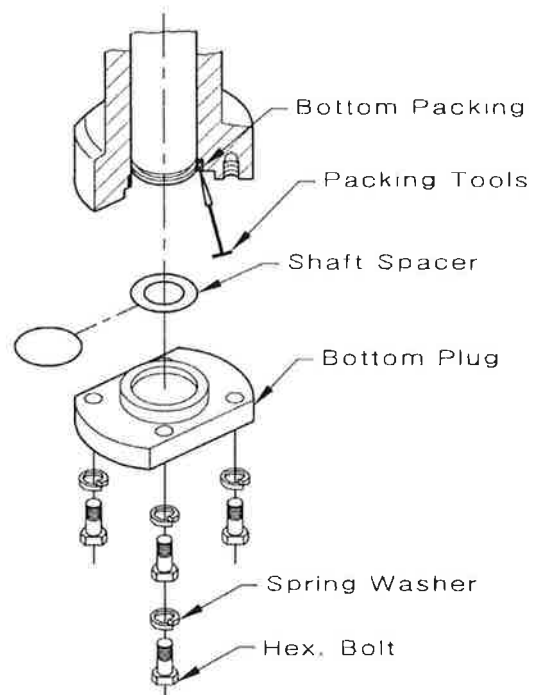

Warning:

Over tightening on the bolt might cause damage of screw thread parts.

③ Seat Replacement :

If flow can't be shut-off at full close position of disc, then seat-damage is suspected. In case of seat-damage, seat replacement work should be followed as below;

- i. See Page 8 (Disassembly of seat / insert ring) for removing a seat and insert ring.
- ii. Please replace the damaged seat with a new one supplied by 'Unicom'.
- iii. New Seat should be seated at the disc opened by 5~10°.

- iv. For assembling the insert ring, please take the reverse steps of the disassembly. Therefore, it is important to identify the location where each part was located before.
- v. Slightly tighten the bolt of insert ring at disc close position and rotate the disc a couple of times.
- vi. Then tighten the bolt completely at the disc opened by 5~10°.
- vii. As a final step, rotate the disc several times to get the seat placed on right position. This would help a seat get the most suitable contact with the disc.
- viii. Install the valve to the pipeline with disc fully closed.

■ **Caution :**

Over tightening bolts may cause a damage of screw thread of bolt and tap of body.

